

**Gilian®**

**BDXII**

**ABATEMENT AIR SAMPLER**



**OPERATION & SERVICE MANUAL**

**SENSIDYNE®**

16333 Bay Vista Dr. • Clearwater, FL 33760 • (800) 451-9444 • (727) 539-0550 [FAX]

**Revision A • Document No. 801863M**

## LETTER FROM THE PRESIDENT

Thank you for purchasing your new Sensidyne air monitoring product. We stand behind all of the products we sell . . . each Sensidyne product has been designed and manufactured to provide unparalleled service, day after day. Our professional staff has tested each unit under the strictest conditions possible to ensure successful, accurate results every time. With the minimal care and maintenance described in this *Operation & Service Manual*, the Sensidyne product you have purchased will give you many years of reliable service.

**Our only goal is that you are pleased with the quality, performance, and accuracy of your Sensidyne product.** Be assured of our complete and prompt answers to any questions you may have about this product, since we are totally committed to providing you with fast, responsive customer service and technical support.

If you ever have difficulty solving a problem with any Sensidyne product, or if you are not 100% satisfied with the service you receive from any level of our organization, please let me know about it. Call me at either of the numbers listed below, and I will personally research your problem to ensure that it is resolved in a manner that is satisfactory to you. Your satisfaction with our products and service is of the utmost importance to me.

Sincerely,

*Carl Mazzuca*

Carl Mazzuca  
President, Sensidyne, Inc.

800-451-9444  
727-530-3602  
Fax: 727-539-0550

## PACKING LIST

The items listed below are shipped with the **Gilian BDXII Abatement Air Sampler**:

- BDXII Abatement Air Sampler
- Tool Kit
- Tubing
- *Operation and Service Manual*

***ALWAYS check to make certain you have received all of the items listed above.***

***If you have any questions or need assistance, contact your Sales Representative, or call***

**(800) 451-9444**

**OR**

**(727) 530-3602**

**PROPRIETARY NOTICE**

This manual was prepared exclusively for the owner of the Gilian BD<sub>XII</sub> Abatement Air Sampler. The material within this manual is proprietary information and is to be used only to understand, operate, and service the instrument. By receiving this document, the recipient agrees that neither this document nor the information disclosed within nor any part thereof shall be reproduced or transferred, physically, electronically or in any other form, or used or disclosed to others for manufacturing or for any other purpose except as specifically authorized in writing by Sensidyne, Inc.

**COPYRIGHT NOTICE**

© 1997 All Rights Reserved. No part of this document may be reproduced, transmitted, transcribed, stored in a retrieval system, or translated into any language in any form by any means without prior written permission of Sensidyne, Inc.

**TRADEMARK NOTICE**

Sensidyne, the Sensidyne logo, Gilian and the Gilian logo are registered trademarks. These trademarks are protected through use and registration in the United States. The trademarks and service marks used in this document are the property of their respective companies and are used only for informational and explanatory purposes.

**DISCLAIMER**

THE SELLER ASSUMES NO RESPONSIBILITY WHATSOEVER, TO ANY PARTY WHOSOEVER, FOR ANY PROPERTY DAMAGE, PERSONAL INJURY, OR DEATH RECEIVED BY OR RESULTING FROM, IN WHOLE, OR IN PART, THE IMPROPER USE, INSTALLATION, OR STORAGE OF THIS PRODUCT BY THE USER, PERSON, FIRM, ENTITY, CORPORATION OR PARTY NOT ADHERING TO THE INSTRUCTIONS AND WARNINGS IN THIS MANUAL, OR OTHERWISE PROVIDED BY THE SELLER OR FROM NOT ADHERING TO ALL FEDERAL, STATE, AND LOCAL ENVIRONMENTAL AND OCCUPATIONAL HEALTH AND SAFETY LAWS AND REGULATIONS.

THE SELLER SHALL NOT BE LIABLE FOR DIRECT, INDIRECT, CONSEQUENTIAL, INCIDENTAL OR OTHER DAMAGES RESULTING FROM THE SALE AND USE OF ANY GOODS AND SELLERS' LIABILITY HEREUNDER SHALL BE LIMITED TO REPAIR OR REPLACEMENT OF ANY GOODS FOUND DEFECTIVE. THIS WARRANTY IS IN LIEU OF ALL OTHER WARRANTIES, EXPRESSED OR IMPLIED, INCLUDING BUT NOT LIMITED TO THE IMPLIED WARRANTIES OF MERCHANTABILITY AND FITNESS FOR USE OR FOR A PARTICULAR PURPOSE WHICH ARE EXPRESSLY DISCLAIMED.

---

**• PREFACE**

---

**• Packing List** ..... 3

**• Notices** ..... 4

**• WARNINGS** ..... 7

---

**SECTION ONE: INTRODUCTION**

---

**1.1 Overview** ..... 8

**1.2 General Description** ..... 8

---

**SECTION TWO: OPERATION**

---

**2.1 Introduction** ..... 11

**2.2 Calibration (Flow Adjust)** ..... 11

**2.3 Operation** ..... 13

---

**SECTION THREE: MAINTENANCE**

---

**3.1 General Maintenance** ..... 14

**3.2 Battery Maintenance** ..... 14

    3.2.1 Battery Charging ..... 16

    3.2.2 Available Battery Chargers ..... 16

**3.3 Filter Maintenance** ..... 17

# TABLE OF CONTENTS

---

## SECTION FOUR: APPENDICES

---

- **Appendix A: Parts List** ..... 18
  - **Appendix B: Specifications** ..... 19
  - **Appendix C: Troubleshooting Guide** ..... 20
  - **Appendix D: Returned Material Authorization**
    - Returned Material Authorization ..... 21
    - Service Options ..... 21
- 

## LIST OF FIGURES

---

- 1.1 BDXII Abatement Air Sampler (Front View) ..... 9
  - 1.2 BDXII Abatement Air Sampler (Side View) ..... 10
  - 2.1 BDXII Pump Calibration (Flow Adjust) ..... 12
  - 3.1 Battery Pack Removal ..... 15
  - 3.2 Internal Filter Maintenance ..... 17
- 

## LIST OF TABLES

---

- 3.1 Estimated Battery Life ..... 16



## WARNINGS



### READ AND UNDERSTAND ALL WARNINGS BEFORE USE

Read and understand **ALL** warnings before using this product. Failure to read, understand, and comply with **ALL** warnings could result in property damage, severe personal injury, or death.

Read and understand **ALL** applicable Federal, State, and Local environmental health and safety laws and regulations, including OSHA. Ensure complete compliance with **ALL** applicable laws and regulations before and during use of this product.

**UNDER NO CIRCUMSTANCES** should this product be used except by qualified, trained, technically competent personnel and not until the warnings, *Operation and Service Manual*, labels, and other literature accompanying this product have been read and understood.

The *Operation and Service Manual must be read and understood by each user before operating this product* or using its accessories, in order to ensure proper and safe use and installation of this product and to ensure familiarity with the proper treatment and safety procedures in the event of an accident.

**DO NOT** remove, cover, or alter any label or tag on this product, its accessories, or related products.

**DO NOT** operate this product should it malfunction or require repair. Operation of a malfunctioning product, or a product requiring repair may result in serious personal injury or death. **DO NOT** attempt to repair or modify the instrument, except as specified in the *Operation and Service Manual*. Contact the Service Department to arrange for a Returned Material Authorization (RMA).

Use **ONLY** genuine Sensidyne replacement parts when performing any maintenance procedures described in this manual. *Failure to do so may seriously impair instrument performance.* Repair or alteration of the product beyond the scope of these maintenance instructions, or by anyone other than an authorized service person, could cause the product to fail to perform as designed and persons who rely on this product for their safety could sustain severe personal injury or death.

**DO NOT** operate in excessive chemical or water vapor atmospheres. Failure to follow instructions may cause permanent damage to the equipment.

The BD $\times$ // Abatement Air Sampling Pump employs rechargeable Nickel-Cadmium batteries. **ALWAYS** fully charge the battery pack before starting the pump.

**DO NOT** operate the unit with improperly maintained batteries. This can cause pump failure or faulting.

**DO NOT** operate the unit with a dirty or blocked inlet filter. This can cause pump failure or faulting.

**DO NOT** drop, crush, or roughly handle the unit, and **NEVER** submerge the unit in water. This can cause pump failure or faulting.

**DO NOT** run the pump beyond its recommended specifications.

# SECTION ONE INTRODUCTION

## 1.1 OVERVIEW

### **IMPORTANT**

*You must read this manual in its entirety to ensure proper operation of your unit.*

This manual contains basic information for operating and maintaining the Gilian BDXII Abatement Air Sampler. The BDXII is capable of delivering up to 3.0 LPM of sample air for periods exceeding 8 hours, with a nominal head restriction of up to 20" of water. Primary application for the Abatement Air Sampler is asbestos sampling, though sampling for emissions, dusts, fumes, and mists is also possible.

The BDXII is designed for maximum utility, simplicity of operation, long service life, and extreme ease of maintenance. Features of the BDXII Abatement Air Sampler include:

- Long life, rechargeable battery pack
- Battery pack rechargeable while attached to unit, or separately
- Belt clip for portability and convenience
- High impact Lexan plastic case for durability
- Light weight construction for comfort when unit is attached to belt
- Built-in, easily readable flowmeter
- Small, long life pump

## 1.2 GENERAL DESCRIPTION

The BDXII Abatement Air Sampler consists of a pump contained in a Lexan plastic case, electronic flow control system, a pneumatic system, and a rechargeable battery pack. The BDXII is shown in Figure 1.1 and Figure 1.2.

The BDXII sampler is equipped with a basic control board, which contains the flow control circuitry. The board also contains the On/Off switch, and the flow control potentiometer.

The pump will normally maintain set flow within  $\pm 5\%$ , with no more than two (2) readjustments needed over an 8-hour period. However, heavy filter media loading may make more frequent readjustments necessary.

The internal/external vent control is located on the top of the sampling pump. You may select the venting control as desired, using the screwdriver provided with the pump. Selecting the open circle position will vent the pump's discharge external to the sampler's case (recommended for moist or corrosive sampling environments). Selecting the closed circle will vent the pump's discharge internally (recommended for dust laden environments).



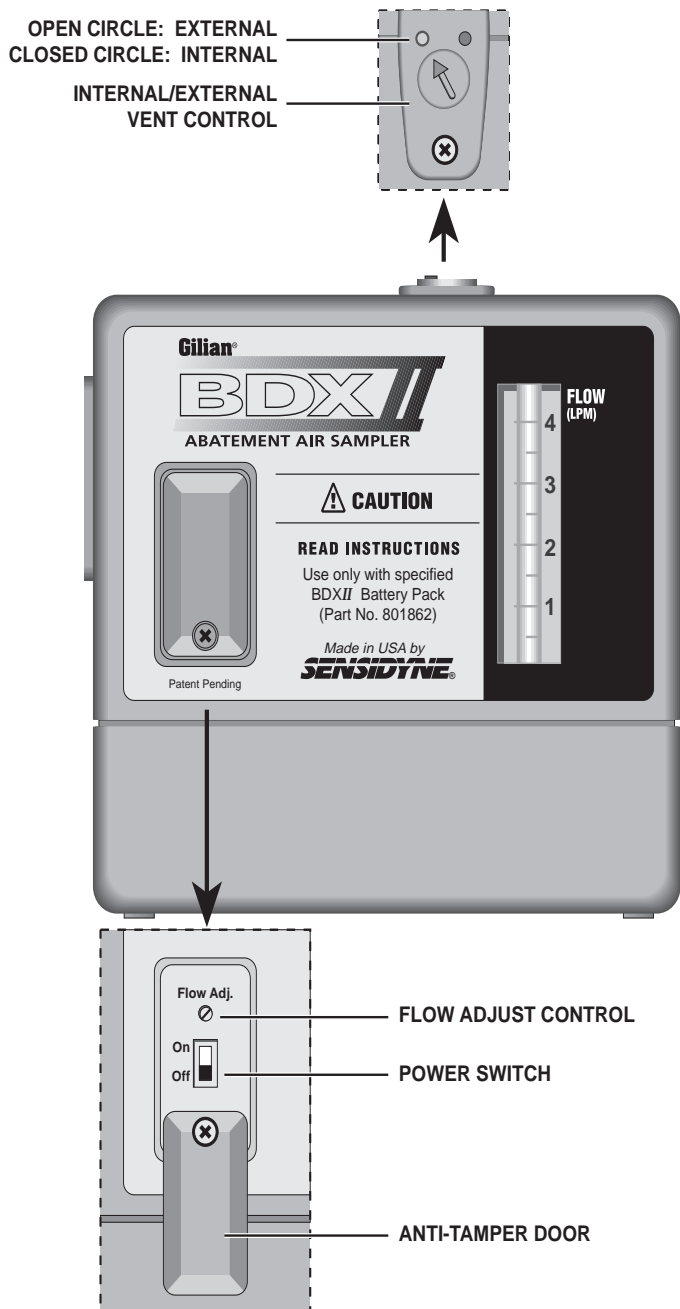

**Figure 1.1**  
**BDXII Abatement Air Sampler (Front view)**

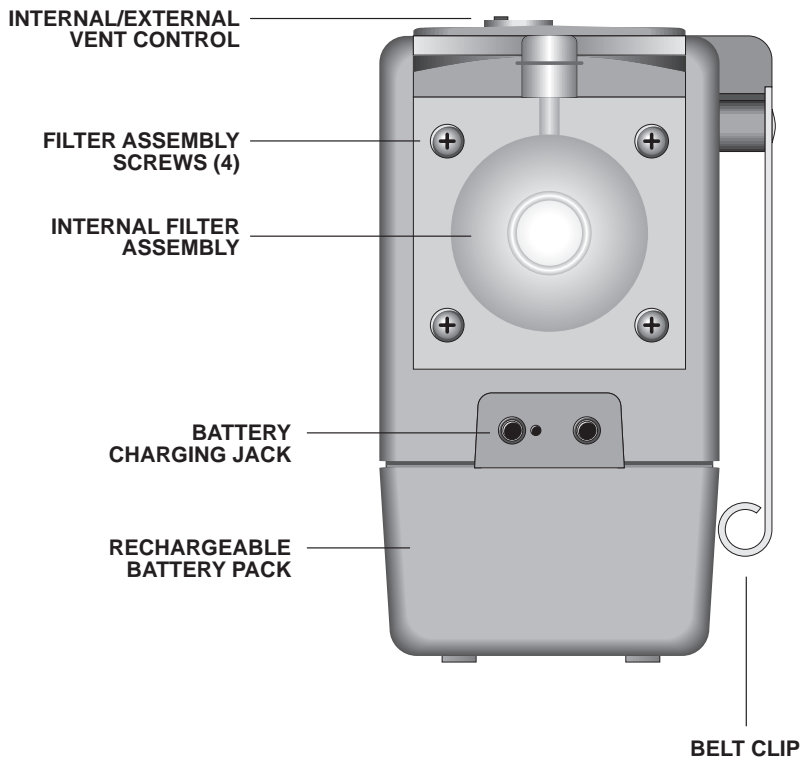

**Figure 1.2**  
**BDXII Abatement Air Sampler (Side view)**

---

**2.1 INTRODUCTION**

---

Before using the BDXII for sampling, the unit must be properly prepared. This includes charging and calibrating the unit for proper flow rate.

When charging the unit make certain that the unit is fully charged. This provides the unit with enough charge to complete a full period of sampling. Follow the general instruction provided in Section Three, as well as the specific instructions provided with the particular charging device used.

---

**CAUTION**

*When charging the device, make certain the AC outlet is nearby and readily accessible.*

---

The BDXII should be calibrated before and after each day of sampling. Calibration should be performed using either an electronic bubble meter (e.g., Gilibrator-2), or a precision rotameter that has been calibrated against an electronic bubble meter.

When a sampling train requires the use of an unusual combination of sampling media (such as a glass fiber filter preceding an impinger), these sampling media should be installed in-line during calibration.

---

**2.2 CALIBRATION (FLOW ADJUST)**

---

To ensure proper operation of the BDXII Abatement Air Sampling Pump, the unit should be properly calibrated prior to sampling.

The calibration (flow adjust) is recommended using a Gilibrator-2 precision electronic flowmeter. If you use a precision bubble meter other than the Gilibrator-2, make certain you follow the instructions that came with your device.

Refer to Figure 2.1 and calibrate the pump as follows:

- 1) Make certain the unit is properly charged.
- 2) Using a small Phillips screwdriver, back out the holding screw just enough so the anti tamper cover plate can be rotated 180°. This exposes the On/Off switch and the flow adjust screw (See Figure 1.1).
- 3) Assemble the cassette filter holder for the sampling media. Use the appropriate filter for the sampling method. Compress the cassette by using a mechanical press or other means of applying pressure. Use shrink tape around the cassette to cover joints and prevent leakage. If a cassette adapter is used, make certain it does not come in contact with the backup pad.

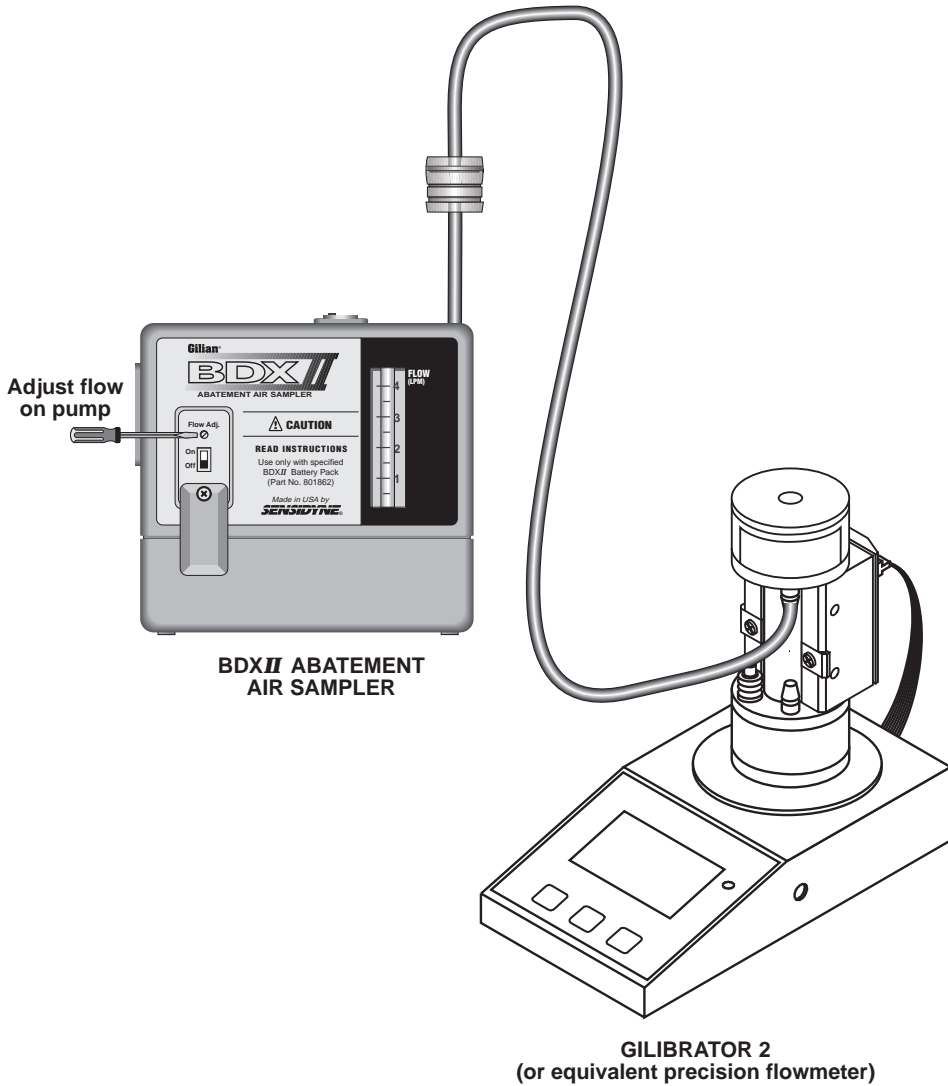

**Figure 2.1**  
**BDXII Pump Calibration (Flow Adjust)**

- 4) Move the On/Off switch to the On position.
- 5) Set the pump flow rate by turning the flow adjust screw (clockwise for increased flow and counterclockwise for decreased flow).
- 6) Use the built-in rotameter on the BDXII as a flow indicator only. Accurate flow adjustment settings must be made by using a Gilibrator-2, or equivalent flow calibration device, for calibration measurements.
- 7) When calibrating the sampler for flow, the sample collection device (cyclone, impinger, filter cassette or sorbent tube) should be in-line.
- 8) When the desired flow rate has been attained, move the On/Off switch to the Off position. The unit is now ready for sample collection.

---

## 2.3 OPERATION

---

Begin the sample run by switching the On/Off switch to the On position. Secure the front anti-tamper cover. The pump will operate at the flow rate set at the last calibration (flow adjustment). The sampling run is terminated by moving the On/Off switch to the Off position.

---

### **NOTE**

*It may be necessary to readjust the flow rate at least 2 times during the sampling period in order to maintain flow within  $\pm 5\%$  of the set flow rate.*

---

After sampling, remove the filter cassette and prepare the cassette filter for analysis. Replace the cassette filter with a clean fresh filter.

Fully charge the battery pack (preferably overnight) to ensure enough power to complete the entire next sampling period. The actual time to achieve a fully charged battery pack depends on the charging device used (see Section Three).

## SECTION THREE MAINTENANCE

### 3.1 GENERAL MAINTENANCE

The BDXII Abatement Air Sampling Pump is relatively maintenance free. Most maintenance involves periodic inspection of the unit, battery maintenance, and filter maintenance.

General inspection involves checking the unit for blockage and pump capacity as follows:

- 1) Examine the unit for physical damage. Make certain that all case components and connections are tight.
- 2) Turn on the pump and check the flowmeter.
- 3) If there is no flow, check all tubing for blockage.
- 4) Check for gross contamination with dust, mud, etc. If contaminated or excessively dirty, replace the internal filter.
- 5) Also, check the Troubleshooting Guide (Appendix C) and make any corrective action. If the problem still exists, return the unit for repair (see Appendix D for obtaining a Returned Material Authorization).

### 3.2 BATTERY MAINTENANCE

The Gilian BDXII Abatement Air Sampler uses rechargeable Nickel-Cadmium batteries. The battery packs must be fully charged and maintained properly to achieve maximum pump run time. The battery pack has an output of 4.8 Vdc and a capacity of 1.8 ampere-hours. *It is incumbent upon the pump user to ensure that the battery pack has enough charge to complete the intended run time.*

The BDXII battery pack is charged through a built-in jack. The jack is located on the side of the unit, below the internal filter assembly. Note that the charging plug is polarized to prevent improper insertion.

#### **CAUTION**

***Do not short the battery terminals or the charging jack. Shorting will result in irreversible damage to the battery pack.***

The battery pack may be charged while attached to the unit or charged separately. Figure 3.1 shows how to remove the battery pack for battery pack replacement or for charging the pack separately from the unit.

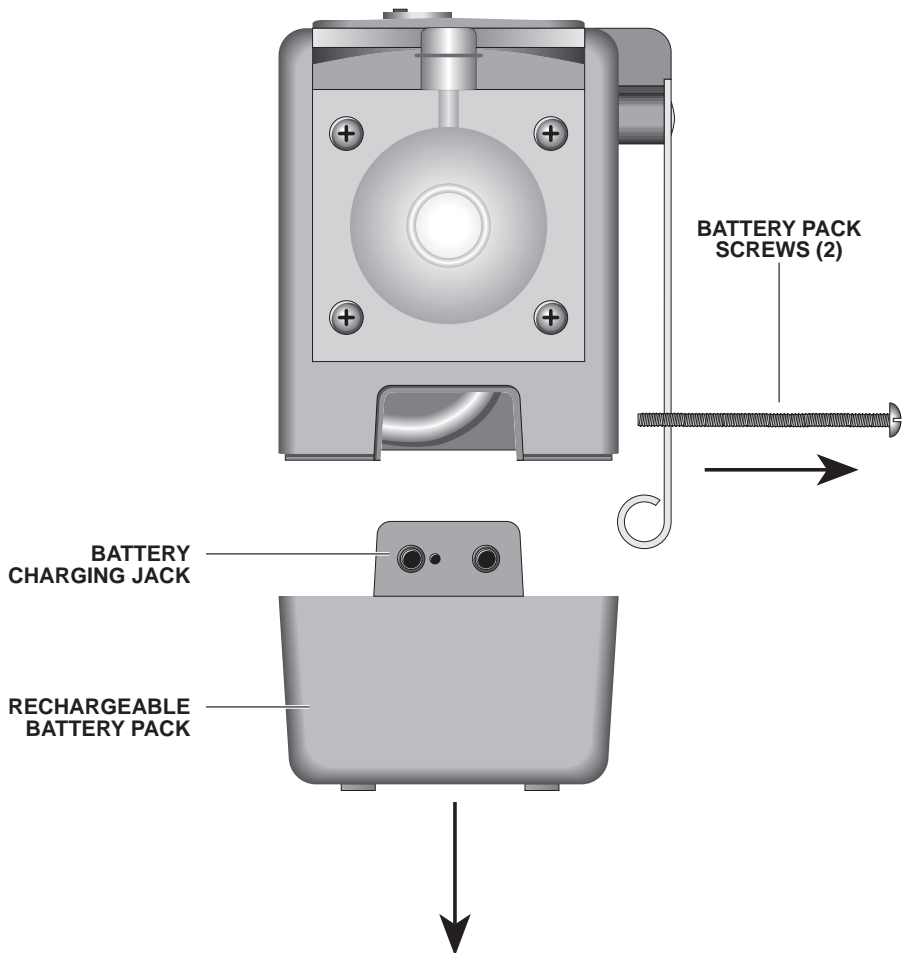

**Figure 3.1**  
**Battery Pack Removal**

**3.2.1 Battery Charging**

• **Battery Life**

Battery life is usually measured in charge/discharge cycles. Gilian battery packs are capable of providing 300–500 charging cycles. Since this is very difficult to track over the life of the battery, Table 3.1 will help you to anticipate how long the battery should last. The estimated battery life is based on proper battery maintenance.

• **Memory Effect**

Nickel-Cadmium batteries will develop reduced capacity when the user does not maintain the practice of fully discharging or fully charging the battery after each use. Memory effect takes time to develop and usually can be eliminated with two discharge/charge cycles.

• **Leakage Current**

Nickel-Cadmium batteries always have a small internal leakage current. If the battery pack has been removed from the charger for more than two days without use, it will require additional charging to restore it to full capacity. This process can be repeated 2–3 times without causing signs of memory effect.

**3.2.2 Available Battery Chargers**

• **Single-Unit Charger**

Single unit chargers provide a constant-rate charge of 190 mA and can fully charge a BDXII battery pack in 14 hours.

• **Universal Multi-Station Charger**

The Multi-Station Charger can charge up to 5 battery packs simultaneously. These chargers provide a timed, constant-rate charge of 180 mA and can fully charge a battery pack in 16 hours. The unit automatically switches to trickle charge (45 mA) as each battery pack becomes fully charged.

• **BMS Multi-Station Charger System**

The BMS Multi-Station Charger & Diagnostic System can charge up to 5 battery packs simultaneously. The BMS offers timed charging that switches to a pulsed charge when the battery pack reaches full charge capacity. Batteries can be charged in under 14 hours. The diagnostic programs provide accurate test data regarding battery voltage under load and battery capacity.

Pump Usage	Weekly Use	Est. Battery Life †
High	40–60 hours	1–1.5 years
Medium	20–39 hours	1.5–2.5 years
Low	< 20 hours	over 2.5 years

† Inactivity for extended periods may shorten battery life.

**Table 3.1  
Estimated Battery Life**



### 3.3 FILTER MAINTENANCE

The BDXII internal filter should be changed whenever it becomes clogged or dirty. The condition of the internal filter is visible through the clear window on the filter assembly.

To change the BDXII filter, refer to Figure 3.2 and follow the steps below.

- 1) Make certain the pump is turned off.
- 2) Remove any tubing attached to the pump.
- 3) Remove the 4 housing screws on the filter housing. Remove the filter housing from the unit.
- 4) Remove the filter O-ring from the filter housing. Remove and discard the old filter.

- 5) Insert a new filter in the filter housing. Make certain the filter is properly centered and flat.
- 6) Insert the filter O-ring in the filter housing. Make certain the O-ring is properly seated.
- 7) Reinstall the center O-ring (orange) in its place on the pump. Make certain it is properly seated.
- 8) Reinstall the filter assembly back on the unit.
- 9) Insert and tighten the 4 screws.

Repeat this procedure on a periodic basis or whenever the filter becomes clogged or dirty.

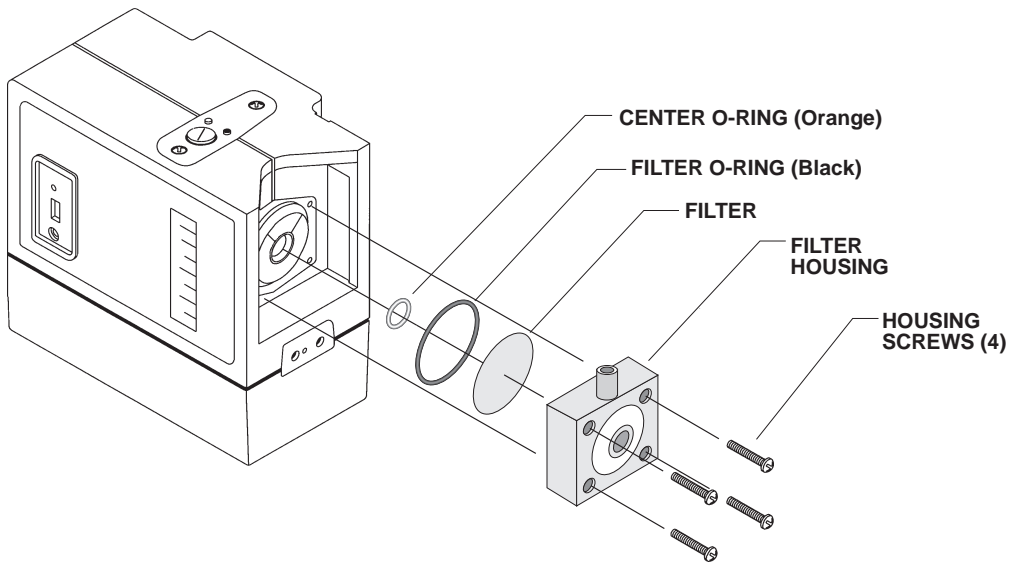

**Figure 3.2**  
**Internal Filter Maintenance**

## APPENDIX A PARTS LIST

Part No.	Description
----------	-------------

801863-120	Abatement Air Sampler Kit (120 VAC)
------------	-------------------------------------

Kit includes: pump, tool kit, single unit charger, tubing and collar clip.

801863-230	Abatement Air Sampler Kit (230 VAC)
------------	-------------------------------------

Kit includes: pump, tool kit, single unit charger, tubing and collar clip.

801863	Abatement Air Sampler (pump only)
--------	-----------------------------------

801862	Rechargeable Battery Pack
--------	---------------------------

402118	Single Unit Charger (120V @ 50/60 Hz), Output: 190 mA
--------	---

402119	Single Unit Charger (230V @ 50/60 Hz), Output: 190 mA
--------	---

850069	Universal Multi-Station Charger (115V 50/60 Hz), Output: 180 mA
--------	---

850070	Universal Multi-Station Charger (230 V 50/60 Hz), Output: 180 mA, "CE"
--------	--

850086	BMS-200, 5-Station Charger (115/230V) Output: 320 mA
--------	--

850086-1	BMS-200, 5-Station Charger (115/230V) Output: 320 mA, "CE"
----------	--

850089	BMS-100B, 5-Station Charger (115/230V) Output: 230 mA (CENELEC)
--------	---

850089-1	BMS-100B, 5-Station Charger (115/230V) Output: 230 mA (CENELEC) "CE"
----------	--

400260	Tool Kit
--------	----------

201050-100	Replacement Filters (pkg of 100)
------------	----------------------------------

800556	Filter Kit
--------	------------

800142	Clip Assembly (3/8")
--------	----------------------

200484	Tubing, 36", 1/4" ID
--------	----------------------

801813M	Operation & Service Manual
---------	----------------------------

\* For further information on spare parts, please contact your Customer Service Representative.

**General Specifications**

Controls .....	Power Switch, Flow Control
Flow Indicator .....	Built-in rotameter, range 500–4000 cc/min, with 500 cc/div @ $\pm 20\%$ Full Scale accuracy.
Additional Features .....	See-through external filter housing, with filter monitoring lens; built-in belt clip.
Dimensions .....	3.6" (W) x 3.9" (H) x 2.0" (D) 90 mm (W) x 100 mm (H) x 51 mm (D)
Weight .....	21 oz. (595 g)

**Power Supply**

Battery Pack .....	4.8 volt, 1.8 amp hour
Battery Type .....	Rechargeable Nickel-Cadmium
Battery Charge Time .....	14–16 hours
Expected Battery Life † .....	300–500 charge/recharge cycles
Estimated Battery Life † .....	2.5 years (< 20 hours weekly use) 1.5–2.5 years (20–39 hours weekly use) 1–1.5 years (40–60 hours weekly use)

† Inactivity for extended periods may shorten nickel-cadmium battery life. Battery life estimates are based on proper battery maintenance.

**Operating Specifications**

Operating Range .....	500–3000 cc/min (0.5–3.0 LPM)
Flow Control .....	$\pm 5\%$ of set point over an 8-hour period, with no more than two (2) readjustments when operating at 2.0 LPM.
Operating Duration (Full Charge) .....	10 hours at 2.0 LPM, with an inlet pressure of up to 20" of water at 21°C (70°F)
Operating Temperature .....	-20°C to 45°C (-4°F to 113°F)
Storage Temperature .....	-40°C to 45°C (-40°F to 113°F)
Charging Temperature .....	5°C to 45°C (41°F to 113°F)

## APPENDIX C TROUBLESHOOTING GUIDE

### Cause

### Remedy

#### • Pump is running but no flow (or reduced flow).

Internal filter may be clogged. Remove obstruction or replace filter.

#### • Unable to adjust flow rate to desired setting.

Sampling filter cassette is clogged. Remove cassette. If flow is now adjustable, replace filter cassette.

System may have leaks. Check for leaks in tubing, assemblies, and internal filter. Repair leaks or replace assemblies, as necessary.

Improperly seated or damaged valves or diaphragm. Return unit to factory for repair.

Pump motor is worn or damaged. Return unit to factory for repair.

#### • Flowmeter float appears to be “stuck.”

System may have leaks. If float is stuck at bottom of flowmeter, identify other symptoms (low or no flow with pump running, etc.) and follow direction accordingly.

Float is stuck. Return unit to factory for repair.

#### • Pump will not run for the specified battery charge life.

Battery pack not properly installed. Disconnect battery pack and re-install it properly.

Battery pack may be damaged or discharged. Charge or replace battery pack, as needed.

Batteries may be exhibiting “memory.” Allow battery pack to fully discharge. FULLY recharge battery pack.

Pump motor is worn. Return unit to factory for repair.

**APPENDIX D**  
**RETURNED MATERIAL AUTHORIZATION**

Sensidyne maintains an instrument service facility at the factory to provide its customers with both warranty and non-warranty repair service. Sensidyne assumes no liability for service performed by personnel other than Sensidyne personnel. To facilitate the repair process, please contact the Sensidyne Service Department in advance for assistance with a problem which cannot be remedied and/or requires the return of the product to the factory. All returned products require a Returned Material Authorization (RMA) number.

Sensidyne Service Department personnel may be reached at:

**Sensidyne**  
**16333 Bay Vista Drive**  
**Clearwater, FL 33760 USA**  
**727-530-3602**  
**727-539-0550 [FAX]**

All non-warranty repair orders will have a minimum fee whether the repair is authorized or not. This fee includes handling, administration and technical expenses for inspecting the instrument and providing an estimate. However, the estimate fee is waived if the repair is authorized.

If you wish to set a limit to the authorized repair cost, state a "not to exceed" figure on your purchase order. Please indicate if

a price quotation is required before authorization of the repair cost, understanding that this invokes extra cost and handling delay. Sensidyne's repair policy is to perform all needed repairs to restore the instrument to its full operating condition.

Repairs are handled on a "first in - first out" basis. Your order may be expedited if you authorize an expediting fee. This will place your order next in line behind orders currently in process.

Pack the instrument and its accessories (preferably in their original packing) and enclose your return address, purchase order, shipping and billing information, RMA number, a description of the problem encountered with your instrument and any special instructions. All prices are subject to change without notice.

If this is the first time you are dealing directly with the factory, you will be asked to prepay or to authorize a COD shipment.

Send the instrument, prepaid, to:

**Sensidyne**  
**16333 Bay Vista Drive**  
**Clearwater, FL 33760 USA**  
**Attention: Service Department**  
**RMA #:** \_\_\_\_\_

**SERVICE OPTIONS**

The Sensidyne Service Department offers you a variety of service options which will help increase your user confidence while minimizing costly interruptions and maintenance costs. These options include initial training, on-site technical assistance, and full factory repairs. Sensidyne has developed several programs which will allow you to select just the right options best suited to your applications and needs. For further information, contact the Sensidyne Service Department.

# ***Notes***





Certificate No. 970084

***SENSIDYNE***<sup>®</sup>

16333 Bay Vista Dr. • Clearwater, FL 33760 • (800) 451-9444 • (727) 539-0550 [FAX]